



▶ 17VXE

Mini Excavator

The 1.7 ton zero tail swing mini excavator with exceptional performance



▶ 17VXE Mini Excavator

The 1.7 ton zero tail swing mini excavator with industry leading specification

FEATURES:

- ▶ Accessible to 980mm wide narrow spaces
- ▶ Powerful bucket digging force : 15.7kN (1600kgf)
- ▶ Excellent work ability for close-skimming
- ▶ Equipped with 3-pump system
- ▶ Comfortable joystick control with armrest
- ▶ Smallest front radius in its class : 1280mm
- ▶ Excellent reach & dump height

Easy Maintenance

- ▶ Wide, fully opening engine-cover enables ease of maintenance
- ▶ Segmented boom cylinder hose design makes replacement easier
- ▶ Corrosion-free, resin fuel-tank
- ▶ Highly anti-corrosive aluminum radiator

Durability

- ▶ Thick rubber tracks provides high durability & life
- ▶ Rugged steel-pressed, engine cover
- ▶ Highly durable blade with extended depth & height travel
- ▶ Bucket cylinder hose built inside the arm

Safety

- ▶ Slew motor with automatic parking brake
- ▶ Gate lock system as standard equipment
- ▶ 4-Post canopy (ROPS) as standard equipment



SPANNER

Retractable dozer blade extension

The blade width can be easily adjusted, offering you the flexibility to fit the job. Adjustment is simple and easy with the two fastening pins.

Equipped with expanding tracks as standard

Expanding from 980mm to 1300mm with an auto lift dozer blade.



ROPS Canopy (Standard)
- 4 Post ROPS canopy as standard



Gate lock system
- Designed to lock all functions



Comfortable operating room
With 20% more leg room



Easy maintenance with large rear access



Removable counter weight



Offset boom - for increased visibility and boom rotation



PROUD TO BE 100%
NEW ZEALAND
OWNED & OPERATED



Two speed selection and track extension selection on joysticks

▶ 17VX Mini Excavator

SPECIFICATIONS:

Dimensions (mm)

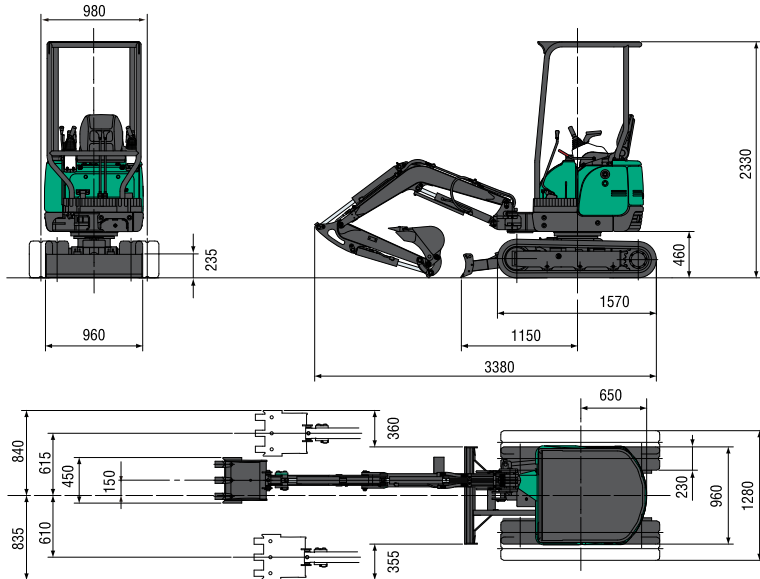

Working Range (mm)

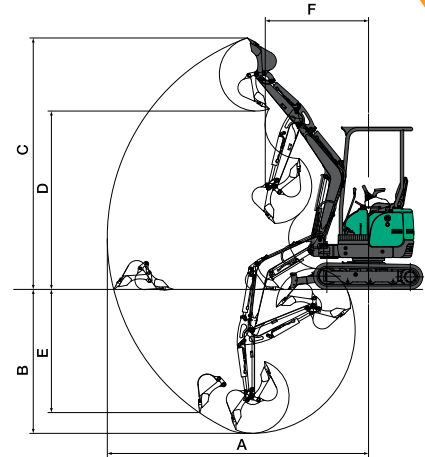

STANDARD:

- 4 post ROPS canopy
- Expanding Tracks
- Flashing Light
- Extra counter weight
- Auxiliary piping

OPTIONS:

- Short dipper arm
- Less counter weight

	Standard	Option (short arm)
4-Post canopy		
A. Max. digging radius	3990	3760
B. Max. digging depth	2350	2100
C. Max. digging height	3810	3610
D. Max. dumping height	2760	2560
E. Max. vertical digging depth	2010	1770
F. Min. front turning radius	1580	1490
At right boom swing	1340	1280

Performance		Boom swing system	
Bucket capacity	0.044m ³	Type	Boom offset with hydraulic cylinder
Bucket width (Standard)	450mm	Swing angle (L/R)	80°/55°
Operating weight: 4-Post ROPS	1730kg	Hydraulic system	
Swing speed	9.5min ⁻¹	Pressure	20.6 Pa (210kgf/cm ²), 18.1 Pa (185kgf/cm ²)
Travel speed (low/high)	2.1/4.0km/h	Pump hydraulic flow	17.2L/min x2 + 12L/min
Gradeability	58%(30°)	Dozer blade	
Ground pressure	26.2kPa (0.27kgf/cm ²)	Size	960mm x 235mm
Max bucket digging force	15.7kN (1600kgf)	Lift above ground / Drop below ground	275mm/310mm
Engine		Max auxiliary flow	
Model	YANMAR 3TNV70	Auxiliary line	29L/min
Rated output	10.5kW/2300min ⁻¹ (14.3PS/2300 rpm)		
Fuel tank capacity	20L		

* Youngman Richardson & Co Ltd reserve the right to change specifications at any time.

PARTS SERVICE:

We are proud of the back-up service we offer to customers. The importance of stocking genuine spare parts for all the equipment we supply is a high company priority.

AUCKLAND HEAD OFFICE
6-10 Parkway Drive,
Mairangi Bay, Auckland
Phone: (+64) 09 443 2436
Fax: (+64) 09 443 2435
Email: sales@yrco.co.nz

SOUTH ISLAND OFFICE
20 Nga Mahi Road,
Sockburn, Christchurch
Phone: (+64) 03 341 6923
Fax: (+64) 03 341 6955
Email: dalel@yrco.co.nz

PROUD TO BE 100%
NEW ZEALAND
OWNED & OPERATED

